

Measuring AM72

Ordering details measuring instrument AM72, type 411 82

Version	Movement	Weight	Order No.
Version direct measurement with 1 x cable entry M25			
0 - 1 / 1.5 A	moving iron	0.70 kg	GHG 411 8281 R0002
0 - 2.5 / 3.75 A	moving iron	0.70 kg	GHG 411 8281 R0003
0 - 5 / 7.5 A	moving iron	0.70 kg	GHG 411 8281 R0004
0 - 10 / 15 A	moving iron	0.70 kg	GHG 411 8281 R0005
0 - 16 / 24 A	moving iron	0.70 kg	GHG 411 8281 R0007
0 - 20 / 24 mA 0-100% / 120% (Ri =320 Ω)	moving coil	0.80 kg	GHG 411 8285 R0033
4 - 20 / 24 mA 0-100% / 120% (Ri =320 Ω)	moving coil	0.80 kg	GHG 411 8286 R0035
Version CT connection n/1A with 1 x entry M25			
0 - 1 / 1.5 A	moving iron	0.70 kg	GHG 411 8282 R0002
0 - 2.5 / 3.75 A	moving iron	0.70 kg	GHG 411 8282 R0003
0 - 5 / 7.5 A	moving iron	0.70 kg	GHG 411 8282 R0004
0 - 10 / 15 A	moving iron	0.70 kg	GHG 411 8282 R0005
0 - 15 / 22,5 A	moving iron	0.70 kg	GHG 411 8282 R0007
0 - 20 / 30 A	moving iron	0.70 kg	GHG 411 8282 R0008
0 - 30 / 45 A	moving iron	0.70 kg	GHG 411 8282 R0009
0 - 40 / 60 A	moving iron	0.70 kg	GHG 411 8282 R0010
0 - 50 / 75 A	moving iron	0.70 kg	GHG 411 8282 R0011
0 - 60 / 90 A	moving iron	0.70 kg	GHG 411 8282 R0012
0 - 75 / 112.5 A	moving iron	0.70 kg	GHG 411 8282 R0013
0 - 100 / 150 A	moving iron	0.70 kg	GHG 411 8282 R0014
0 - 100% / 150%	moving iron	0.70 kg	GHG 411 8282 R0001

Dimension drawing

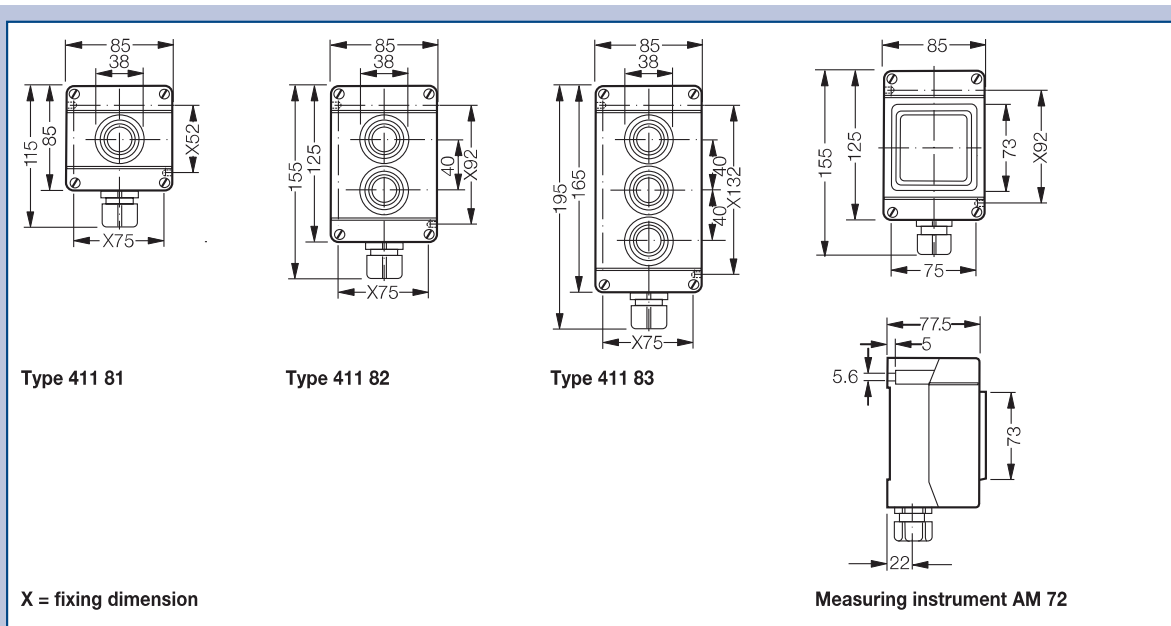

Dimensions in mm

1
2
3
4
5
6
7
8
9
10
11
12